

In SWATYCOMET grinding wheels for grinding of new rolls and renewal of rolls in usage are produced. Our technology and production facilities enable us production of grinding wheels in vitrified and resinoid bond up to the diameter of 1300 mm. For final grinding of new rolls we recommend two different granulations, a rough and a fine one, whereby the grits used depend on the size of the grinding wheel. Due to different types of bonds implemented grinding wheels can be used at peripheral speeds from 25 to 63 m/s. For special materials such as ASP and WIDIA we produce tools with CBN and DIAMOND abrasives up to the diameter of 600 mm. To achieve targeted grinding results we suggest the usage of dressing tools from our production programme. The shape of ordered grinding wheel is adjusted to the design of the machine or to the specific requirements of the customer.

Shape types and dimensions for individual types of grinding machines.

Standard types:

Type: 1
DxTxH

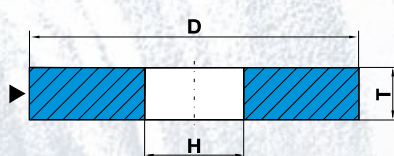

Type: 5
DxTxH-PxF

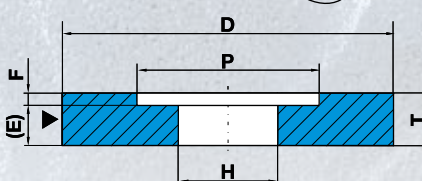
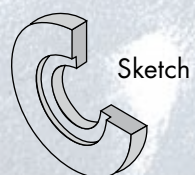

Type: 7
DxTxH-PxF/G

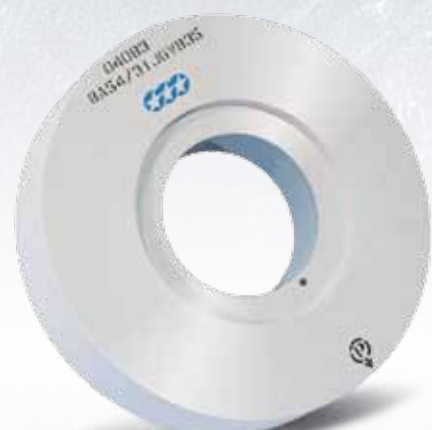
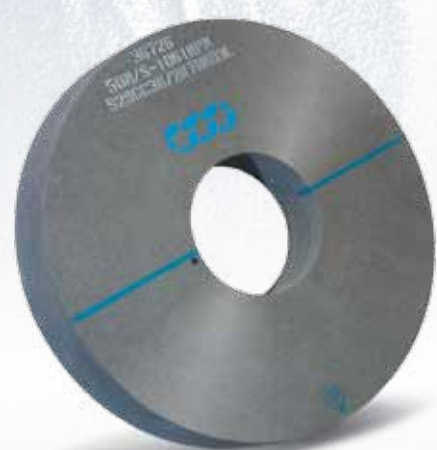
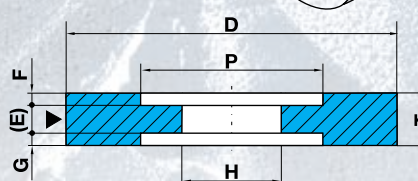
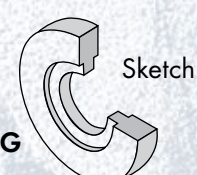

Dimensions:

D (mm)	T (mm)	H (mm)
350	38	127
600	50/60/70/100/125	203.2/304.8
700	60/80/100/125	304.8
750	80/100/125	304.8
762	80/100/125	304.8
800	80/100/125	304.8/381
900	80/100/150	304.8/355/457.2
920	80/100/127/150	304.8/355/457.2/508
1000	60/75/80/100/127/150	304.8/355/457.2/508
1065	80/100/127	406.4

Machines:

Waldrich
Herkules
Landis
Schauth
Cerchil
Fortuna
Farrel
and others.

The range of grinding wheel qualities

Production of rolls

Casting	Rough grinding	51C16/4R4B18
	Final grinding	C80/3H9V60
Steel	Rough grinding	8A54/3I17V835
	Final grinding	C120/1H11V60

Steel production

Hot milling - renewal of rolls

Working rolls	Casting	Standard	S29GC36/2J7BX03
		High stock removal	S29GC36/2J7BX03
	Fine	Standard	S9C36-60K7BX03
		High stock removal	S29GC36-60J7BX03
Forged rolls	Rough grinding	S2A46/3K7BM03	
	Rough grinding	S2A60/3J7BM03	
	Final grinding	C80/2I7V60	

Cold milling - renewal of rolls

Working rolls	Standard	S2A46/3K7BM03
	High stock removal	S68C36-60 J-B
Back up rolls	Standard	S2A46/3K7BM03

Sendzimir rolls

Thrust bearings	68C60J-B
Back up rolls	68C60J-B
Drive rolls	68C60J-B
Intermediate rolls	68C60J-B
Working rolls	S29GC100/1F10BX03
Working rolls - fine grinding	9C180/9E11BX50/300
Chromium cast rolls	2A60/3J7V
ASP working rolls	102B 46-151R100B47S
WIDIA working rolls	101D 46-151R100B40S

Copper and aluminium mills

Plate	2A60-80 H10/3V35 (standard)	8A54-60I7V835 (high stock removal)
Sheet	9C150-180G-H10/3V35	



Grinding of rubbered rolls

Hard rubber	2A30/1G13/1V
Hard rubber - fine grinding	2A54/1G13/1V
Soft rubber	1A24/1I7+V
Soft rubber - fine grinding	C60/1G13/1V
Calender rolls	8A60/1H8/6V

Radial and axial roll surface grinding



Sketch of type 36

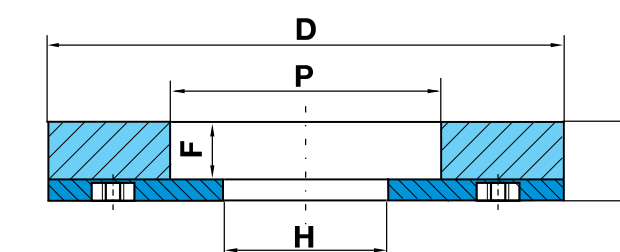

Sketch of shape SGY

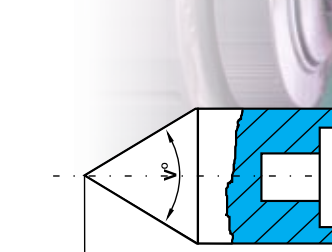

Grinding of threaded center bores in rolls

Type / Dimension SGY / DxTxH-V	Quality
18x35	8A120/2L9V835
26x38	8A120/2L9V835
50x39	8A120/2L9V835

Type / Dimension	Quality
36-DxTxH-PxF	8A36/2J8V835

Useful suggestions

Grinding wheel peripheral speed

Material	Grinding	m/sec	Infeed - mm/feed	Longitudinal feed
Casting	Rough production grinding	45-63	0.25	1000 mm/min
	Fine	35-50	0.010-0.020	5000 mm/min
	Renewal grinding	35-40	0.010-0.030	3000 mm/min
Steel	Rough production grinding	35-63	0.020-0.030	5000 mm/min
	Fine renewal grinding	25-30	0.002-0.005	3000 mm/min

Cooling:

Quantity in l/h	200-600 l/min (depending on the D of the grinding wheel)
Pressure	3-5 bar
Nozzle	Minimal T of grinding wheel x 3 mm

Dressing of Grinding Wheels



Useful suggestions

- PDE**
Single point dresser
- PDM**
Multicrystal diamond
- PDM-Rolette**
Diamond rolette
(Rotating diamond dresser)

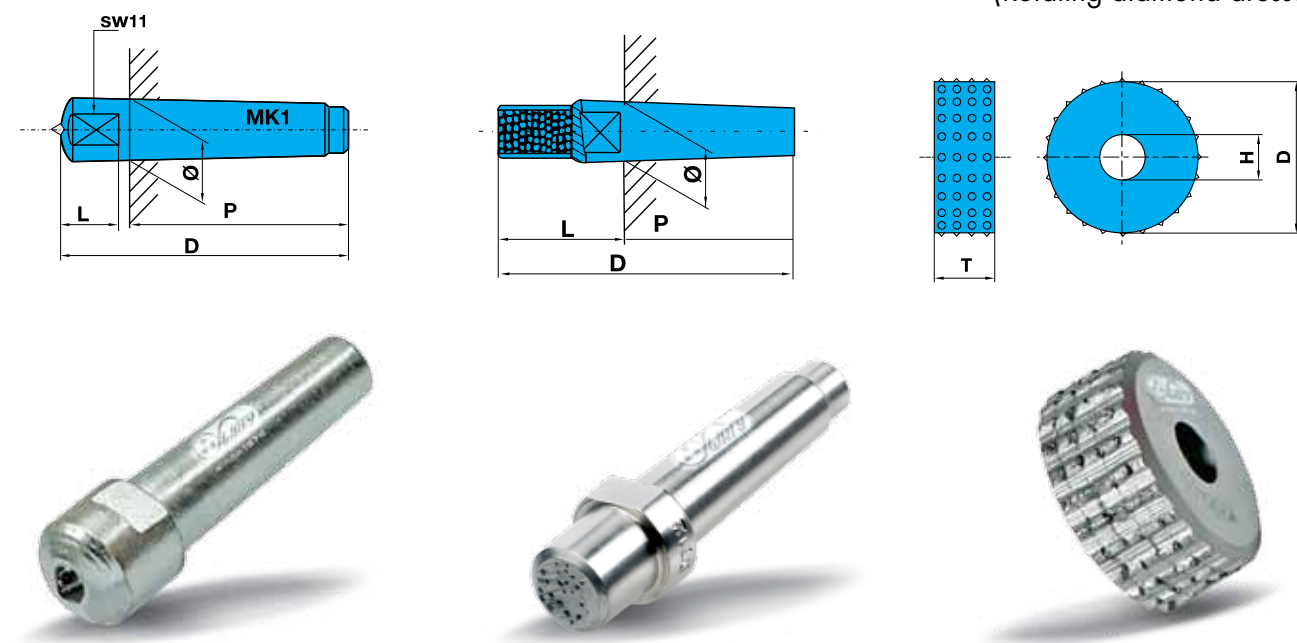

Type of dressing tool

Casting	Rough production grinding	Single point dresser
	Repair grinding	Multicrystal
Steel	Rough production grinding	Multicrystal
	Final production grinding	Multicrystal

Dressing of grinding wheel

Grinding wheel peripheral speed	25-30 m/sec
Infeed	0,05-0,01 mm
Longitudinal feed	300-500 mm/min
Number of feeds	3-5

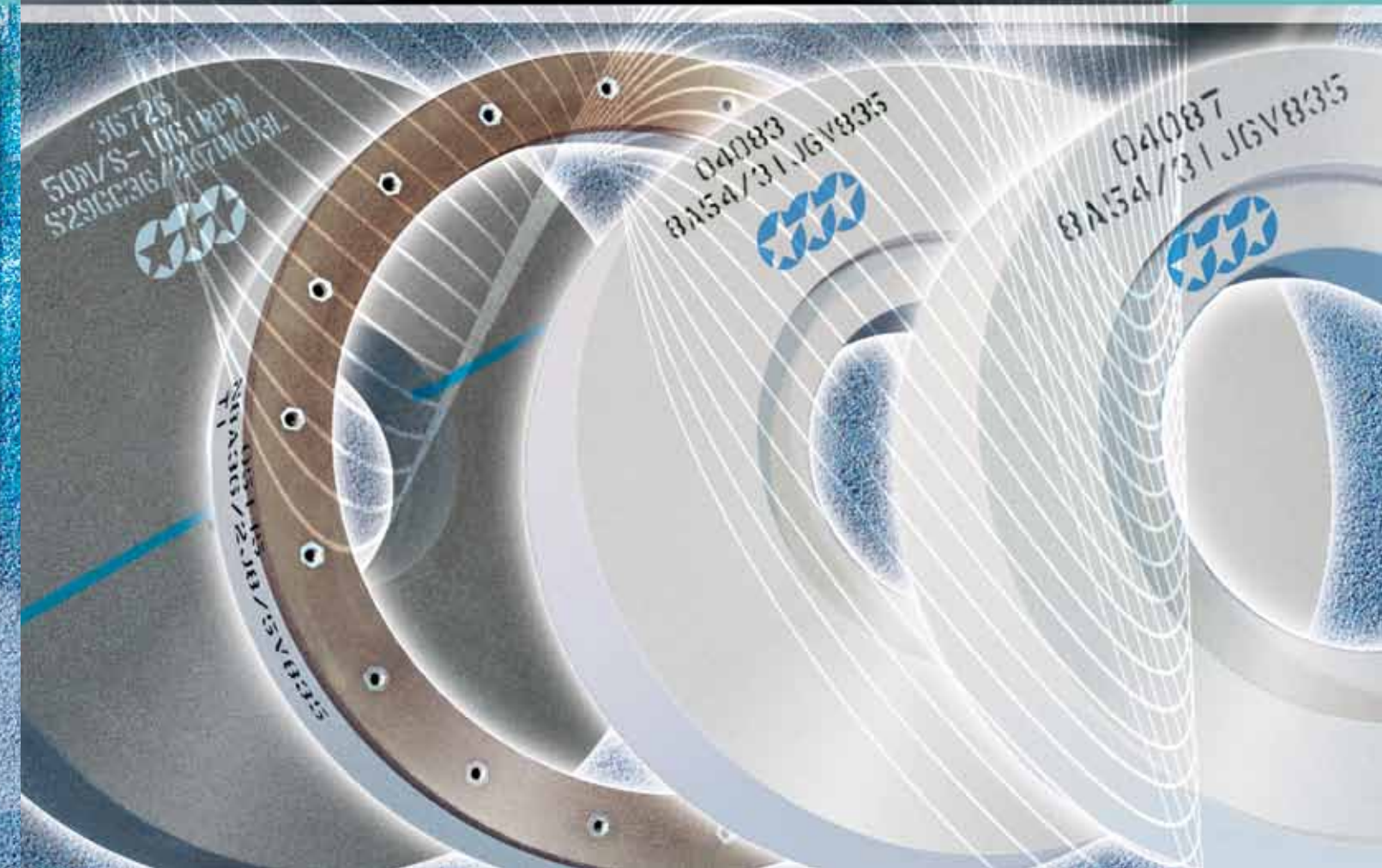

SWATYCOMET, umetni brusi in nekovine, d.o.o.
 Titova cesta 60, 2000 Maribor, Slovenija
 t: +386 (0)2 333 16 00, +386 (0)3 7575 000
 f: +386 (0)2 333 17 90, +386 (0)3 7575 100
 www.swatycomet.si, e: info@swatycomet.si

